ISOLATED DIGITAL INPUT & FET OUTPUT BOARDS FOR MINI PCI EXPRESS HARDWARE MANUAL

MODELS

MPCIE-IDIO-8 MPCIE-IDO-8 AND MPCIE-IDIO-4



CHAPTER 1: QUICK START

It is recommended that you install the software package before installing the PCI Express Mini Card (mPCIe) in your computer. You can install the software¹ using either a stand-alone installer downloaded from the website or an optional Software Master CD.

Run the installer you downloaded (or autorun.exe on the Software Master CD) and follow the prompts to install the software for your device.

Please note: during the installation you may be prompted regarding the installation of non-WHQL-certified drivers; please carefully confirm the digitally signed source of the drivers and accept the installation.

Once the software has been installed, shut down your system and carefully install the mPCIe card.

Re-start your system. Once the computer finishes booting your new device should already be installed and ready for use; you can confirm this by launching Device Manager and looking under the “Data Acquisition” section. If, for any reason, the mPCIe displays a warning icon, right-click and select “Update Driver”.

¹ In Linux or OSX please refer to the instructions in those directories.

CHAPTER 2: INTRODUCTION

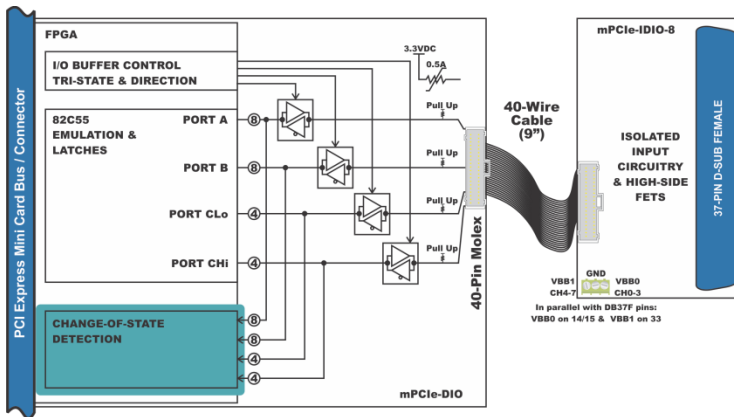

PCI Express Mini Card (mPCIe), a low-profile small-footprint bus standard originally intended for adding peripherals to notebook computers, has become the de-facto standard for high-performance, small form-factor devices in many applications.

This device consists of an mPCIe interface board that connects to a Mobile-ITX-sized, panel-mountable, DB-37F Isolation Module via an included 9” cable.

FEATURES

- 8 or 4 optically-isolated non-polarized inputs
- 8 or 4 FET outputs
- 8 or 4 LVTTTL I/O lines programmable as inputs or outputs in groups of 4 lines
- 9” cable (228mm), standard
- Panel-mountable DB-37F Isolation Module
- All inputs support Change-of-State (CoS) IRQs

The mPCIe-IDIO cards are well suited to complex environments, mitigating otherwise challenging ground-loops, high-common-

mode, and transient voltage spikes common in electrically-noisy industrial or factory locations. The broad voltage compatibility and high current outputs allows use in a wide range of applications.

The non-polarized inputs support both AC and DC, and configuration jumpers allow 4.7ms input filters to be enabled per-channel, as desired – required for AC use. The Isolated Inputs support voltages from 3 to 31 VDC/VAC RMS [40Hz to 10000Hz], as well as standard 12/24 AC control transformer signals.

The outputs are High-Side Power MOSFETs capable of 2A continuous-current load.

Switching a FET from the ON to OFF or from OFF to ON is a digital

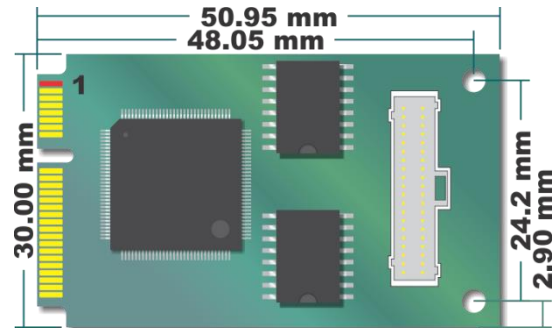

operation, and is therefore relatively fast, best measured in microseconds.

CHAPTER 3: HARDWARE

This manual applies to the following models:

- mPCIe-IDIO-8 8 Isolated Input, 8 FET Output mPCIe Card
- mPCIe-IDO-8 8 FET Outputs on mPCIe Card
- mPCIe-IDIO-4 4 Isolated Input, 4 FET Output mPCIe Card

These models are full-length “F1” mPCIe devices (30 × 50.95 mm), and include a required 9” (229mm) 40-conductor cable connected to a panel-mountable DB-37F Isolation Module. The Isolation Module is Mobile-ITX sized (1.772” x 2.952”) for broad installation compatibility. All units are RoHS compliant.

INCLUDED IN YOUR PACKAGE

- Panel-mountable DB-37F Isolation Module w/screw locks
- 9” 40-pin cable (228mm)
- Digital I/O mPCIe card

Available accessories include:

- ADAP37M, STB-37 37-pin Screw Terminal Accessories
- mPCIe-HDW-KIT2 Mounting hardware for 2mm
- mPCIe-HDW-KIT2.5 Mounting hardware for 2.5mm

Contact the factory for information regarding additional accessories, options, and specials that may be available to best fit your specific application requirements, such as extended temperature, conformal coating, or alternate cable lengths, to name a few.

CHAPTER 4: CONFIGURATION SETTINGS

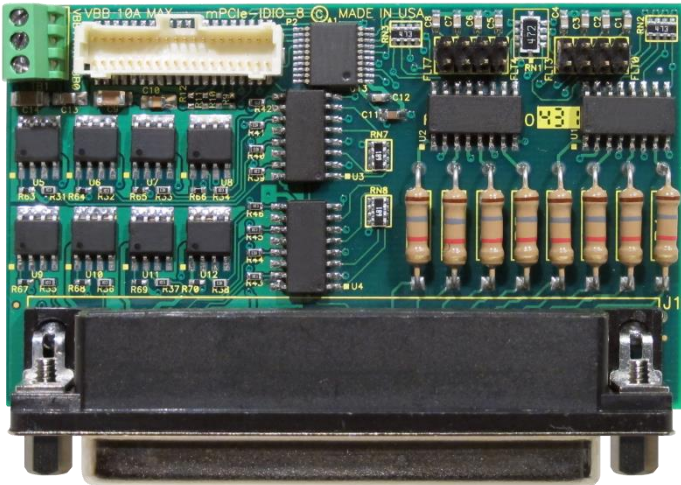

The Isolation Module includes jumpers to enable input filters with a 4.7ms time-constant, optimized for dealing with AC signals, but useful for a wide variety of transient-mitigation tasks.

There is one filter option selection jumper per input channel; simply move the provided jumper plug to the ON position to enable filtering for the respective channel. The first group of four jumpers as shown in the above photograph apply to input channels 7 down through 4; the second group to channels 3 through 0.

CHAPTER 5: PC INTERFACE

This product interfaces with a PC using a PCI Express Mini Card (mPCIe) connection; a small-form-factor, high-performance, rugged peripheral interconnect technology first introduced for use in laptops and other portable computers.

mPCIe's small size and powerful performance, combined with perfect software compatibility with PCI and PCIe peripheral designs, have led to its recent adoption as a go-to standard for embedded Data Acquisition and Control, and many other applications.

Although mPCIe is a broadly-adopted industry standard, the actual connection to the computer shares a specification with mSATA: both mSATA and mPCIe use the same edge-connector. In fact, well-designed PCs can automatically detect and configure their onboard connectors to work with either mPCIe or mSATA devices – and, according to the standards for mPCIe and mSATA they are *supposed* to do so! However, some PC manufacturers ship computers that *only* support mSATA devices. Please confirm in your PC documentation that your edge-connector is *actually* PCI Express Mini Card compliant before installing this, or any, mPCIe card. Damage might occur if you install a mPCIe device into a computer that only supports mSATA.

mPCIe defines mounting holes for securing the otherwise loose end of the card, so it is impossible for these cards to wiggle or flap themselves loose (which was a recurring problem with the older PCI Mini devices). Eliminating this concern for PCI Express Mini Cards is a major reason this standard has seen rapid adoption by the Data Acquisition and Control industry.

The mPCIe standard, like its PCI Mini Card predecessor, was designed assuming use primarily in Laptop or Notebook and similar devices, where physical dimension is often the paramount design

constraint. In Data Acquisition and Control applications low-weight combined with vibration tolerance tend to be of more concern.

CHAPTER 6: I/O INTERFACE

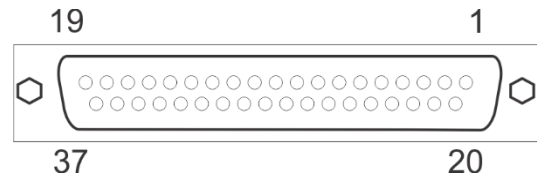

Signal Definitions	
Signal	Meanings
IN A #	Non-Polarized Isolated Input "A" Side
IN B #	Non-Polarized Isolated Input "B" Side
OUT +	FET Output pin
RETURN	OUT - for all FETs (0-7)
VBB 0*	Compliance Voltage for FETs 0-3
VBB 1	Compliance Voltage for FETs 4-7
LV TTL	Digital I/O pin (3.3VDC, +5VDC tolerant)
I/O #	

DB-37F Female Pinout			
1	IN A 7		
2	IN A 6	20	IN B 7
3	IN A 5	21	IN B 6
4	IN A 4	22	IN B 5
5	IN A 3	23	IN B 4
6	IN A 2	24	IN B 3
7	IN A 1	25	IN B 2
8	IN A 0	26	IN B 1
9	GND	27	IN B 0
10	LV TTL 0	28	LV TTL 4
11	LV TTL 1	29	LV TTL 5
12	LV TTL 2	30	LV TTL 6
13	LV TTL 3	31	LV TTL 7
14	VBB 0*	32	RETURN
15	VBB 0*	33	VBB 1
16	OUT + 0	34	OUT + 4
17	OUT + 1	35	OUT + 5
18	OUT + 2	36	OUT + 6
19	OUT + 3	37	OUT + 7

Custom hardware interfaces can be produced to fit your specific application requirement.

*note: Layout concerns dictate no more than 2.5 Amps be sourced through each VBB0 pin. VBB1 supports the full 5A on the single pin. It is acceptable to always connect your source to both VBB0 pins.

Example: Shared AC or DC power with multiple contacts monitored

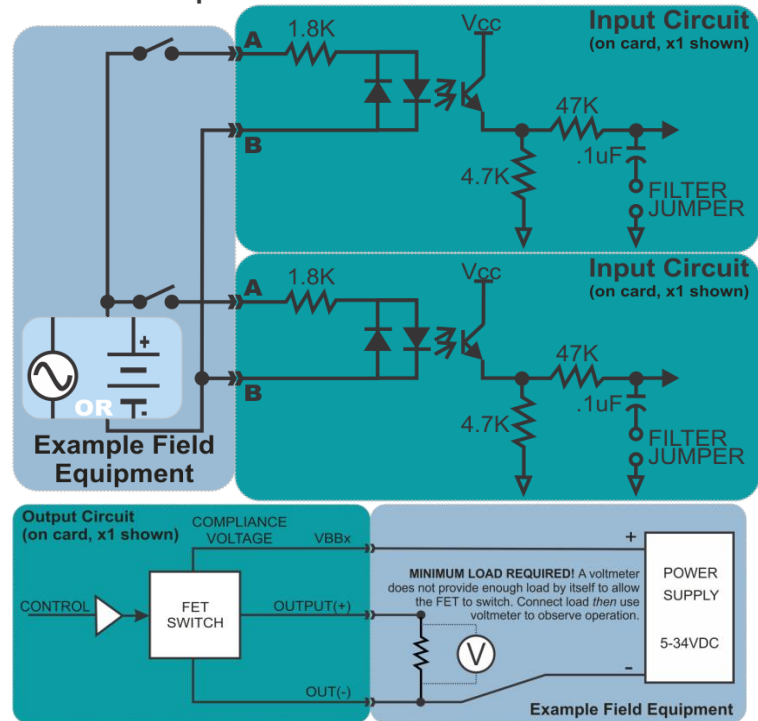

TB1 provides an alternate location for connecting VBB0 and VBB1 in parallel with the DB37F pins. You may find the screw terminals more convenient when sourcing power from inside your enclosure.

CHAPTER 7: SOFTWARE INTERFACE

The simplest way to program for the device is using legacy-compatibility mode: the device boots into this mode, and you can control it exactly like you would a PCIe-IDIO-8, or a PCI-IDIO-8 – or even a 104-IDIO-8!

I/O Registers at BAR [2]		
Register offset (decimal)	Write Operation	Read Operation
FETs [+ 0]	FET 0-7 output	FET 0-7 read-back
Isolated Inputs [+ 1]	unused	Bits 0-7 input
TTL 0-3 and 4-7 [+ 16]	Digital Output	Digital Input
TTL Control [+ 17]	Configure Port I/O	Read I/O Config.
IRQ Control [+40]	En- / Dis-able IRQ	
IRQ Clear/Status [+41]	Clear IRQ	IRQ Status

In the following bit-level register descriptions the column labeled “Dir” indicates read or write operation, with the following notation:

R: Read function, and W: Write function. RW indicates both.
r: read, and w: write, but less-commonly useful than R or W

+ 0	Dir	D7	D6	D5	D4	D3	D2	D1	D0
FET #	rW	7	6	5	4	3	2	1	0

Writing one byte to +0 will control all 8 FETs. Setting a bit to 1 energizes the corresponding FET, while clearing a bit to 0 turns the FET off. Reading a byte will provide the currently commanded FET state (read-back).

+ 1	Dir	D7	D6	D5	D4	D3	D2	D1	D0
Input #	R	7	6	5	4	3	2	1	0

Reading from +1 returns 8 bits. Each set bit indicates current was detected at the corresponding isolated input.

+ 16	Dir	D7	D6	D5	D4	D3	D2	D1	D0
Input #	RW	7	6	5	4	3	2	1	0

Writing to this register will output the bits to the TTL output pins. Any bit configured as input will ignore the operation. Reading this register will return the state of the input pins, and/or will read back the state of the any pin configured as outputs.

+ 17	Dir	D7	D6	D5	D4	D3	D2	D1	D0
TTL DIR	rW							TTL4-7	TTL0-3

Writing a “1” to bit D0 or D1 will configure the corresponding TTL bits as output. Writing a “0” will configure the port for use as inputs. All pins are configured as inputs at power-up or reset.

Reading this register will give the current input vs output configuration.

+ 40	Dir	D7	D6	D5	D4	D3	D2	D1	D0
IRQ En	rW	IRQ ENABLE							

Writing “FF” will enable IRQs on the 8 Isolated Input bits, as well as any TTL bits configured as input. Write 00 to disable.

+ 41	Dir	D7	D6	D5	D4	D3	D2	D1	D0
IRQ Clr	W	Write 0xFF to clear pending IRQs							
IRQ Stat	R	INT							

Write “1” to each IRQ status bit to clear the pending IRQ. Bits D1 through D7 are reserved, for best results write “1” to all bits (0xFF).

Reading will give the current IRQ latch state. Bit D0 “1” means “an IRQ was generated”.

In addition to the I/O registers at BAR[2], BAR[0] contains one register for compatibility with the PCIe product line: Register +0x69 contains a read-only status bit [d7] which indicates the card is generating an IRQ when set [1], and is not generating an IRQ when clear [0].

All of these registers can be operated from any operating system using any programming language, using either no driver at all (kernel mode, Linux ioperm(3), DOS, VxWorks, etc.) or using one of the ACCES provided drivers (AIOWDM [for Windows], [APCI](#) or [AIOComedi](#) [for Linux & OSX]), or using any 3rd party APIs such as provided with Real-Time OSes.

In Windows¹, please consult the various samples (C#, Delphi, VC6, VB6, and more) to explore how to program the device. The Software Reference Manual.pdf provides reference material covering all AIOWDM driver APIs, and tips for simplifying tasks such as Plug-and-Play card detection. Please note that the Software Reference Manual.pdf will include numerous functions that don’t apply to this device. A quick reference of the most-applicable functions is provided, below:

AIOWDM API Quick Reference	
Function name	Function Purpose
ReI nPortB()	Read 8-bits of data
ReI OutPortB()	Write 8-bits of data
QueryCardInfo()	Determine what cards AIOWDM has detected in the system
waitForIRQ()	Block the thread until the device reports a change-of-state has occurred on a pin of an enabled I/O group (or the wait is aborted).

There are quite a few additional functions provided by AIOWDM.dll; please consult the Software Reference manual (.pdf), and/or the sample programs, for more information.

Under certain circumstances the following information might prove useful:

PCI Express Mini Card Plug-and-Play Data	
Vendor / Device ID	Card Type
0x494F / 0x0100	mPCIe DIO Base

Available Downloads

The latest information can always be found on the product page on the website. Here are some useful links:

Links to useful downloads	
Main site	http://aces.io
Product’s page	aces.io/mPCIe-IDIO-8
This manual	aces.io/MANUALS/mPCIe-IDIO-8.pdf
Windows Software Install Package	aces.io/files/packages/mPCIe-IDIO Install.exe

¹ In Linux or OSX please refer to the documentation at github.com/acesio/AIOComedi.

CHAPTER 8: SPECIFICATIONS

PC Interface

PCI Express Mini Card Type F1 "Full Length" V1.2

Note: Device's connector violates component height restrictions

Isolated Inputs

Number	8 (or 4)
Type	Non-polarized, optically isolated from each other and from the computer (CMOS compatible)
Voltage	3 to 31 DC or AC RMS (40 to 10000Hz)
Isolation	500V channel-to-ground and ch-to-ch
Resistance	1.8KΩ in series with opto-coupler

Filter Response

Rise-time	4.7 ms
Fall-time	4.7 ms

Non-Filter Response

Rise-time	10 μs
Fall-time	30 μs

FET Outputs & Digital I/O Lines

Number	8 (or 4)
Type	High Side Power MOSFET Switch. Protected against short-circuit, over-temp, ESD; can drive inductive loads.
Voltage Range	5-34VDC recommended (customer supplied) for continuous use, 40VDC absolute maximum
Current Rating	2A maximum
Turn On time	90μsec (typical)
Turn Off time	110μsec (typical)

CHAPTER 9: CERTIFICATIONS

CE & FCC

These devices are designed to meet all applicable EM interference and emission standards. However, as they are intended for use installed on motherboards, and inside the chassis of industrial PCs, important care in the selection of PC and chassis is important to achieve compliance for the computer as a whole.

UL & TUV

No AC or DC voltages above 31V are consumed or produced during normal operation of this device. This product is therefore exempt from any related safety standards. Use it with confidence!

ROHS / LEAD-FREE STATEMENT

All models are produced in compliance with RoHS and various other lead-free initiatives.

WARNING

A SINGLE STATIC DISCHARGE CAN DAMAGE YOUR CARD AND CAUSE PREMATURE FAILURE! PLEASE FOLLOW ALL REASONABLE PRECAUTIONS TO PREVENT A STATIC DISCHARGE SUCH AS GROUNDING YOURSELF BY TOUCHING ANY GROUNDED SURFACE PRIOR TO TOUCHING THE CARD.

ALWAYS CONNECT AND DISCONNECT YOUR FIELD CABLING WITH THE COMPUTER POWER OFF. ALWAYS TURN COMPUTER POWER OFF BEFORE INSTALLING A CARD.

Digital Inputs 8 or 4 LVTTTL	Logic High Logic Low	2.0V to VCCIO (3.3VDC, 5VDC tolerant) 0V to 0.8V
Digital Outputs 8 or 4 LVTTTL	Logic High Logic Low	2.0V (min) 24mA source 0.55V (max) 24mA sink

Environmental

Temperature	Operating	0°C to 70°C (order "-T" for -40° to 85°C)
	Storage	-65° to 150°C
Humidity		5% to 95%, non-condensing
Power required		+3.3VDC @ 360mA (typical)

Physical

mPCIe board characteristics		
Weight		6.2 grams
Size	Length	50.95mm (2.006")
	Width	30.00mm (1.181")
I/O connector	On-card mating	Molex 501190-4017 40-pin latching Molex 501189-4010
Isolation Module characteristics		
Weight		38.2 grams (+11.2g for the 9" cable)
Size (Mobile-ITX sized)	Length	2.952"
	Width	1.772"
I/O connector	On-module mating	Female, D-Sub Miniature, 37-pin Male, D-Sub Miniature, 37-pin

CONNECTING AND DISCONNECTING CABLES, OR INSTALLING CARDS, INTO A SYSTEM WITH THE COMPUTER OR FIELD POWER ON MAY CAUSE DAMAGE TO THE I/O CARD AND WILL VOID ALL WARRANTIES, IMPLIED OR EXPRESSED.

WARRANTY

Prior to shipment, ACCES equipment is thoroughly inspected and tested to applicable specifications. However, should equipment failure occur, ACCES assures its customers that prompt service and support will be available. All equipment originally manufactured by ACCES which is found to be defective will be repaired or replaced subject to the following considerations:

GENERAL

Under this Warranty, liability of ACCES is limited to replacing, repairing or issuing credit (at ACCES discretion) for any products which are proved to be defective during the warranty period. In no case is ACCES liable for consequential or special damage arriving from use or misuse of our product. The customer is responsible for all charges caused by modifications or additions to ACCES equipment not approved in writing by ACCES or, if in ACCES opinion the equipment has been subjected to abnormal use. "Abnormal use" for purposes of this warranty is defined as any use to which the equipment is exposed other than that use specified or intended as evidenced by purchase or sales representation. Other than the above, no other warranty,

expressed or implied, shall apply to any and all such equipment furnished or sold by ACCES.

TERMS AND CONDITIONS

If a unit is suspected of failure, contact ACCES' Customer Service department. Be prepared to give the unit model number, serial number, and a description of the failure symptom(s). We may suggest some simple tests to confirm the failure. We will assign a Return Material Authorization (RMA) number which must appear on the outer label of the return package. All units/components should be properly packed for handling and returned with freight prepaid to the ACCES designated Service Center, and will be returned to the customer's/user's site freight prepaid and invoiced.

COVERAGE

FIRST THREE YEARS: Returned unit/part will be repaired and/or replaced at ACCES option with no charge for labor or parts not excluded by warranty. Warranty commences with equipment shipment.

FOLLOWING YEARS: Throughout your equipment's lifetime, ACCES stands ready to provide on-site or in-plant service at reasonable rates similar to those of other manufacturers in the industry.

EQUIPMENT NOT MANUFACTURED BY ACCES

Equipment provided but not manufactured by ACCES is warranted and will be repaired according to the terms and conditions of the respective equipment manufacturer's warranty.

DISCLAIMER

The information in this document is provided for reference only. ACCES does not assume any liability arising out of the application or use of the information or products described herein. This document may contain or reference information and products protected by copyrights or patents and does not convey any license under the patent rights of ACCES, nor the rights of others